

PT Torishima Guna Indonesia
Jl. Rawa Sumur Timur No.1
Pulogadung Industrial Estate
Jakarta 13930
T. +62 21 460 6448
F. +62 21 460 3964
E. marketing@torishima.co.id
www.torishima.co.id

CAL (Cast Iron)

CAR (Stainless Steel)

End-Suction Volute Pump



CAR



CAL

The Torishima "Eco Pumps" lead the World!

End-Suction Volute Pump (10 bar type)

CAL is of Cast Iron construction. CAR is of Stainless Steel construction.

CA series pumps are eco-friendly high-efficiency pumps based on technology from our engineered pumps.

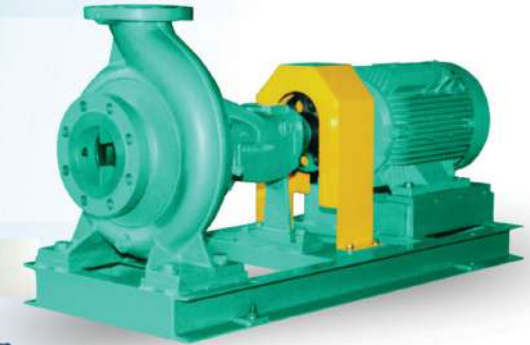

Energy Saving & Cost Reduction

Eco pumps significantly reduce the life cycle costs of pumps and CO₂ emissions because of their design (3D impeller, casing), motor (Torishima ultra high efficiency motor) and optimized specification (impeller cut).

Reduction of LCC (Life Cycle Cost)

About 90% of the pump LCC is generated from electricity cost. Increased efficiency leads to big reduction of LCC.

LCC composition

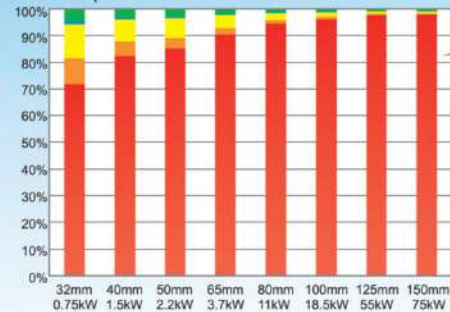

About 90% of pump LCC is electricity cost.

LCC is calculated on the basis of:
CAL size 32 to 150mm;
24hours day, 365days, 15years operation;
Operating at 60Hz-4P with normal temperature clean water;
Electricity cost of JPY10 per kWh.

Operating cost: Electricity (red), Maintenance (orange), Spare parts (yellow)
Initial cost: Installation work (blue), Unit price (green)

Energy Saving with Eco Pumps

Cooling water pump

Annual operating hours: 8,760hours

	Existing pump spec		Torishima pump CAL125-250		Difference
	Motor capacity	30kW	30kW		
Capacity(m ³ /min)	4.7	4.7	4.7	0%	
Head(m)	26.5	27.7	26.5	-1.2m	
Pump efficiency(%)	78	81	81	+3.0%	
Shaft power(kW)	27.2	25.1	25.1	-2.1kW	
Motor efficiency(%)	91.9	94.5	94.5	+2.6%	
Power consumption(kW)	29.6	26.6	26.6	-3.0kW(-10.1%)	
Annual Power Consumption(kWh)	269,296	233,016		-26,280kWh	

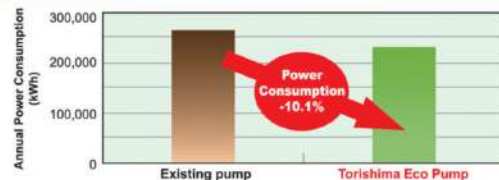

Annual Saving
USD\$2,628
(= 26,280 kWh x USD 0,1)

Electricity cost per kWh : USD 0,1

Annual CO₂ Reduction
11.8t-CO₂
(=26,280kWh x 0.00045t-CO₂/kWh)

Conversion factor of CO₂ emission: 0.00045 (t-CO₂/kWh) referred from Tokyo Electric Power Co., Inc, 2011

Meeting Customer's Specification (Impeller cut)

The impeller diameter can be cut to meet the customer's specification to reduce unnecessary power consumption.

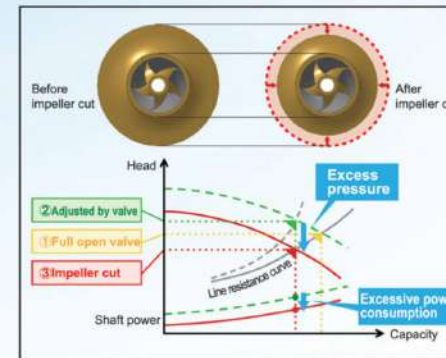

High Speed and Simplified Design

CAL/CAR are simplified with high speed and compact design, which enable to reduce the installation space.

Low NPSH and a Wide Application Range

Low NPSH performance enables lower suction level which reduces plant construction cost.

CAL/CAR can handle liquid temperatures from -40 to +350°C (heat medium) and various liquid types.

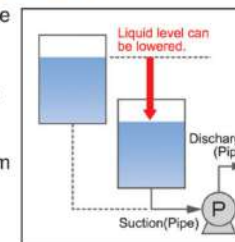

Maintenance & Operation

Mechanical Seal as Standard Part

Maintenance free.

No leakage from seal parts allows cleanliness around pumps.



Standard mechanical seal (rubber bellows seal) is easy to install and does not damage shaft, thus does not require shaft sleeve.

	Mechanical seal	Gland packing
Leakage	0 cc/min	15 cc/min
5-year leakage	0 £	39,420 £
Cost amount	USD\$ 0	USD\$ 138*

* In case of using tap water
- Industrial Water : USD\$ 17,74 (USD\$ 0,45/m³)
- Tap Water : USD\$ 138 (USD\$ 3,5/m³)
- Pure Water : USD\$ 591,000 (USD\$ 151)

39,420£ leakage from using gland packing for 5 years equals to about 197 bathtubs (200£ home bathtub)



Safe Operation with Precision Bearing Design

Stable Operation

The stable pump performance facilitates valve control and parallel operation.

Coupling Guard

CAL/CAR are covered with and enclosed type coupling guard as an optional

An enclosed coupling guard improves safety and maintenance compared to an existing coupling guard due to the wide area of coverage



Standard Coupling Guard



Enclosed Coupling Guard
(as optional)



TU Motor : 2P-55kW or less, 4P-110kW or less
Coupling Diameter : 280 mm or less
Motors have different size and frame by manufacturers

Downsizing to 2P Design

Increasing the pump speed by using a 2 pole motor reduces the pump size and weight.

Conditions: total head of 50m, capacity of 1m³/min, and 60Hz

Pole number: 4P
Pump size: CAL80-400
Motor output: 18.5kW
Weight: 400kg

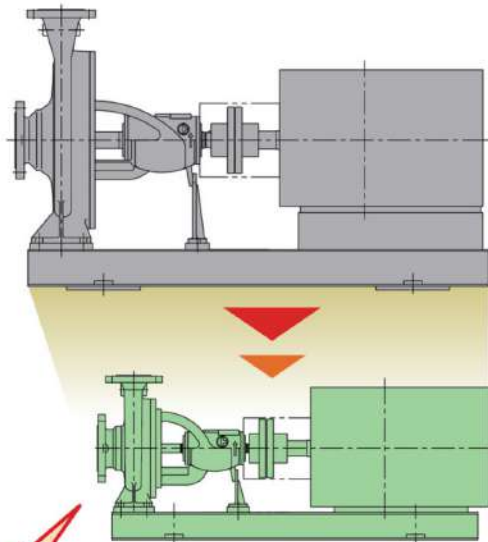

Pole number: 2P
Pump size: CAL50-200
Motor output: 15kW
Weight: 209kg

**Weight reduced by 47%
compared to 4P**
= (400-209) ÷ 400 × 100



The above diagram describes characteristics of 2P. We can provide the design for 4P as well.
Weight includes pump, base plate, motor and coupling.
Motor weight differs depending on manufacturers.

Applications

Utility	Co-generation	Cooling water pump, Hot water (circulation) pump	CAL
	Air conditioning	Cold water pump, Cooling water pump, Hot water pump	
	Drainage treatment	Raw water pump, Filtrate pump, Back wash pump, Transfer pump	CAR
	Pure water facility	Raw water pump, RO wash pump, Recovering back wash pump, Filtrate water pump	
Iron & Metal	Power generation	Deaerator feed water pump	CAL
	Hot rolling	Transfer pump, Hot water pump, Water pumping pump, Filtrate pump, Back wash pump,	
	Flue gas desulfurization	Cooling water pump, Industrial water pump	CAR
	Roll coolant	Spray pump	
	Plating	Wash pump (Rinse pump)	
Food & Beverage	Manufacturing process	Cold water pump, Cooling water pump (Circulation / Boost), Recycle water pump, Filtrate pump, Sprinkling pump	CAL
	Refrigerator	Chilled pump, Defrost pump	CAR
	CIP system	CIP supply / return pump	
Automobile (Painting Plant)	Degreasing process	Degreasing pump, Hot / Cold water wash pump, Spray pump	CAR
	Transformation process	Chemical pump, Hot / Cold water wash pump, Pure water pump	
	Electrodeposition process	Electrodeposition liquid circulation pump, Wash pump, Pure water pump	
Garbage Incinerating Plant	Power generation	Deaerator feed water pump, Condensate pump,	CAL
	Heat decrease tower	Heat decrease pump, Spray pump for heat decrease tower	
	Drainage	Reuse water pump (pumping, transferring, feeding)	
Other Liquid Handled		Brain, Acetone, Calcium chloride, Kalium chloride, Alkaline solution, Ethylene glycol, Agua fortis, Sulfate, Sodium hydroxide, Ammonia liquor, Caustic soda, etc.	CAR

Please ask about special fluid.

Specification

		CAL(Cast Iron) 	CAR(Stainless Steel) 
Handled liquid	Kinds	Clean water, Warm water, Oil, Chemical medicine, Alkaline solution, Brine, Heat transfer media, Abrasive slurry liquid under 3wt%, etc.	Pure water, Hot water, Sea water, Salted water, Refrigerant, Electrodeposition paint, Abrasive slurry liquid under 3wt%, etc.
	Temperature	Standard: -10°C < T ≤ 100°C Option: 100°C < T ≤ 350°C	Standard: -10°C to +80°C Option: -40°C to +140°C
Max. discharge pressure		Standard: 1MPa (10kgf/cm ² G) Option: 1.4MPa (14kgf/cm ² G)	1MPa (10kgf/cm ² G)
Max. suction pressure		0.8MPa (8kgf/cm ² G)	0.8MPa (8kgf/cm ² G)
Design	Impeller	Closed	Closed
	Shaft seals	Standard: Single mechanical seal (Rubber bellows) Option: Double mechanical seal, Gland packing	Standard: Single mechanical seal (Rubber bellows) Option: Double mechanical seal, Gland packing
	Water injection for shaft seal	Standard: Internal injection Option: Quenching, Flushing	Standard: Internal injection Option: Quenching, Flushing
	Lubricated bearing	Standard: Grease lubrication Option: Oil lubrication	Standard: Grease lubrication Option: Oil lubrication
Flange standard, Suction / Discharge direction		JIS 10KRF Shaft direction suction / Vertical top discharge	JIS 10KRF Shaft direction suction / Vertical top discharge
Pump material	Casing	Standard: FC250 Option: FCD400	Standard: SCS13 Option: SCS14
	Impeller	Standard: FC200 Option: SCS13, SCS14, BC6	Standard: SCS13 Option: SCS14
	Shaft	Standard: SUS420J2 Option: SUS329J1, SUS304	Standard: SUS304 Option: SUS316, SUS329J1
	Case wear ring	Standard: FC200	—

Design Features

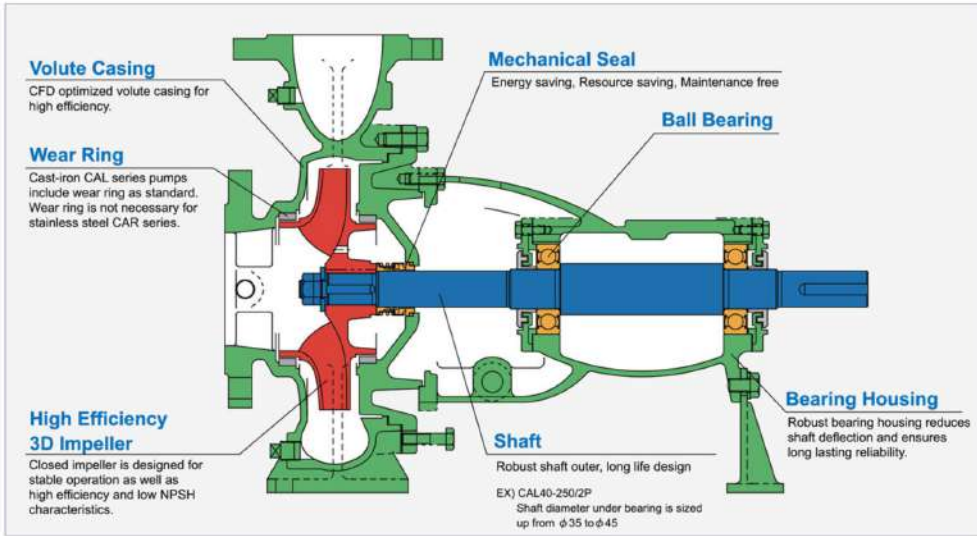

Pump Sectional Drawing

The basic structure is same between CAL and CAR for parts interchangeability. CAR, which is made from stainless, does not require case wear ring. Due to adopting build to order method, various combination with pump material, seal and bearing is available according to liquids kinds and temperature.

Standard Seal: Mechanical seal
Bearing: Grease lubrication

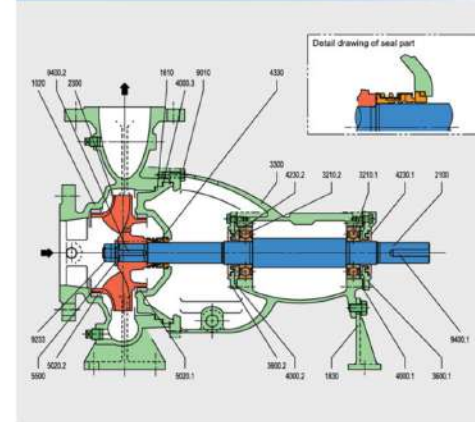

Option Seal: Mechanical seal + Water cooling
Bearing: Oil lubrication

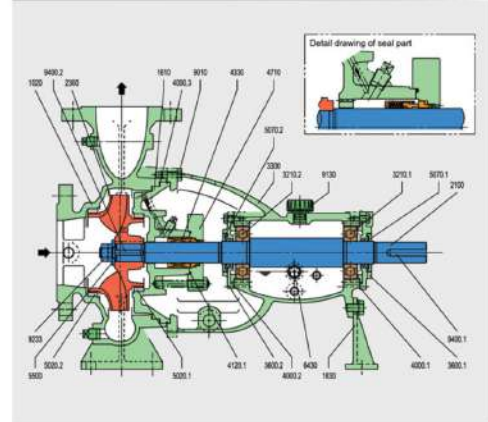

Parts Interchangeability

2P type Same color and number in the same parts indicate interchangeability.

Parts Pump type	Casing	Casing Cover	Bearing Housing	Shaft	Mechanical Seal
32-125	1				
40-125	2	1			
65-125	3				
32-160	4				
40-160	5	2	1	1	1
50-160	6				
32-200	7				
40-200	8	3			
50-200	9				
80-160	10	4	2	2	
80-200	11	5			
32-250	12				2
40-250	13	6	3	3	
50-250	14				
80-250	15	7			

4P type Same color and number in the same parts indicate interchangeability.

Parts Pump type	Casing	Casing Cover	Bearing Housing	Shaft	Mechanical Seal
32-125	1				
40-125	2	1			
65-125	3				
32-160	4				
40-160	5	2	1	1	1
50-160	6				
65-150	7				
32-200	8				
40-200	9	3			
50-200	10				
85-190	11	4			
80-150	12				
80-190	13	5			
100-190	14				
32-250	15				
40-250	16	6			
50-250	17				
65-240	18				
80-240	19	7	2	2	2
100-245	20				
100-250	21				
50-315	22				
65-310	23	8			
80-320	24				
100-320	25	9			
150-190	26		3	3	3
125-240	27	10			
125-250	28				
200-240	29				
200-250	30	11	4	4	
125-310	31				
125-315	32	12			
80-400	33	13	3	3	
100-400	34	14	4	4	
125-400	35				
150-310	36	15	5	5	4
150-315	37				
150-390	38				
150-400	39	16			

Option Seal: Double mechanical seal
Bearing: Oil lubrication

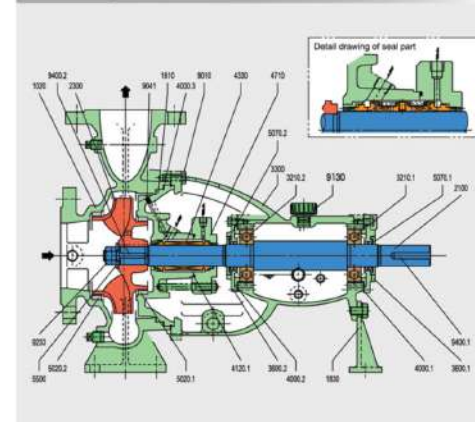

Option Seal: Gland packing
Bearing: Grease lubrication

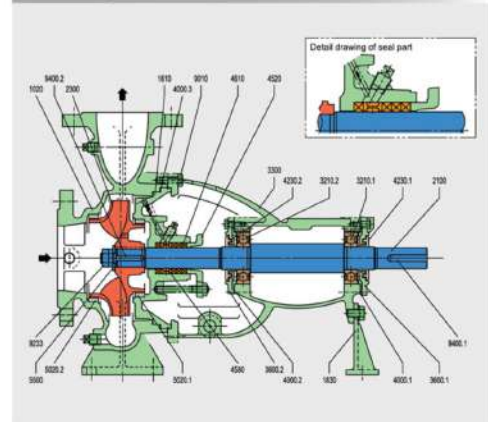

Parts number	Parts name	Parts number	Parts name	Parts number	Parts name	Parts number	Parts name
1020	Volute casing	3600.2	Bearing cover	4580	Lantern ring	9010	Hex. bolt
1610	Casing cover	4000.1	Flat gasket	4610	Gland packing	9041	Nock
1830	Support foot	4000.2	Flat gasket	4710	Seal cover	9130	Plug
2100	Shaft	4000.3	Flat gasket	5020.1	Casing wear ring	9233	Lock nut
2300	Impeller	4120.1	O-ring	5020.2	Casing wear ring	9400.1	Key
3210.1	Deep groove ball bearing	4230.1	Labyrinth ring	5070.1	Deflector	9400.2	Key
3210.2	Deep groove ball bearing	4230.2	Mechanical seal	5070.2	Deflector		
3300	Bearing housing	4330	Shaft box gland	5500	Bearing housing		
3600.1	Bearing cover	4520		6430	Oil gauge		

Dimension Chart

■ Flange standard CAL : JIS10K RF / CAR : JIS10K RF

■ Below dimension is based on totally enclosed fan-cooled motor.

■ Motors have different size and frame depending on manufacturers.

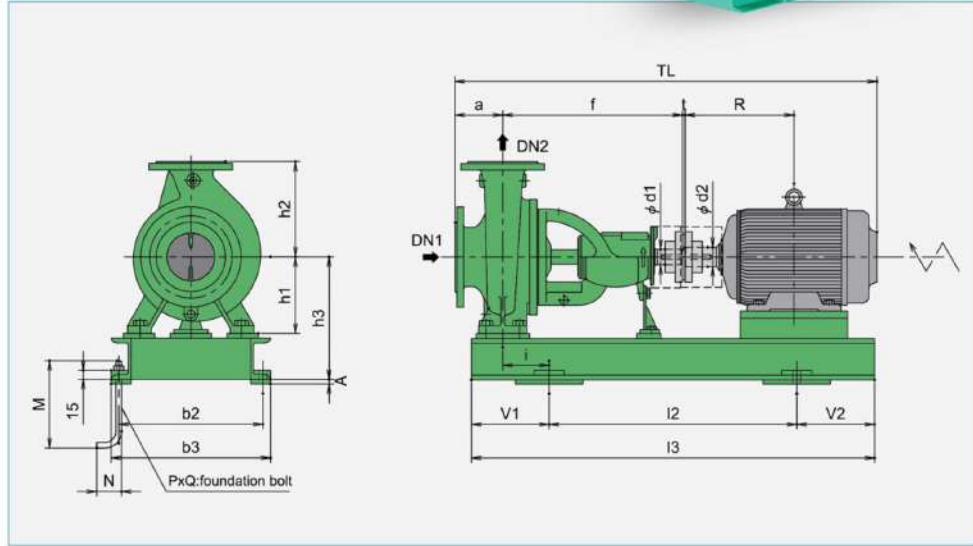

Dimension Chart for 2P Motor Drive

Pump Sizes	Pump							Axle		Weight		Motor			Base Plate					Foundation Dimensions							Coupling		Refer.	
	Bore		Dimension			d1	Grade L	Grade R	kg	kg	Dimension			A	Wt.	h3	i	b2	I2	M	N	P	Q	V1	V2	t	Wt.	TL		
	DN1	DN2	a	f	h1						h2	R	R																	d2
32-125 40-125	50 65	32 40	80 80	360 360	112 112	140 140	24 24	27 28	28	---	71M	120	14	320	670	0	27	202	45	290	420	200	50	4	MI2	105	145	3	1.1	681
										80M	140	19	320	670	0	27	202	45	290	420	200	50	4	MI2	105	145	3	1.1	725.5	
										80M	140	19	320	670	0	27	202	45	290	420	200	50	4	MI2	105	145	3	1.1	705	
										90S	156	24	320	750	0	28	202	55	290	480	200	50	4	MI2	115	155	3	1.1	750.5	
										90L	168.5	24	320	750	0	28	202	55	290	480	200	50	4	MI2	115	155	3	1.1	775.5	
										100L	193	28	320	750	0	28	202	55	290	480	200	50	4	MI2	115	155	3	1.6	809	
										112M	200	28	320	750	0	27	202	55	290	480	200	50	4	MI2	115	155	3	1.6	834.5	
										132S	239	38	350	870	0	32	219	90	320	600	200	50	4	MI2	150	120	3	3.2	897	
										80	140	19	320	670	0	28	222	45	290	420	200	50	4	MI2	105	145	3	1.1	745.5	
										80M	140	19	320	670	0	28	222	45	290	420	200	50	4	MI2	105	145	3	1.1	725	
										90S	156	24	320	750	0	30	222	55	290	480	200	50	4	MI2	115	155	3	1.1	770.5	
										90L	168.5	24	320	750	0	30	222	55	290	480	200	50	4	MI2	115	155	3	1.1	795.5	
32-160 40-160 65-125	50 65 80	32 40 50	80 80 100	360 360 360	132 132 160	160 160 180	24 24 24	28 30 31	30 31 33	---	100L	193	28	320	750	0	29	222	55	290	480	200	50	4	MI2	115	155	3	1.6	829
										112M	200	28	320	750	0	28	222	55	290	480	200	50	4	MI2	115	155	3	1.6	854.5	
										132S	239	38	350	870	0	31	222	90	320	600	200	50	4	MI2	150	120	3	3.2	917	
										160M*	323	42	430	1000	0	41	250	110	400	660	200	50	4	MI2	170	170	3	6.7	1071	
										160M**	323	42	430	1000	0	41	250	110	400	660	200	50	4	MI2	170	170	3	6.7	786	
										160L	345	42	430	1000	0	41	250	110	400	660	200	50	4	MI2	170	170	3	6.7	1115	

*Motor frame is the same but shaft axle diameter (d2) is different.

Pump Sizes	Pump							Axle		Weight		Motor			Base Plate					Foundation Dimensions							Coupling		Refer.	
	Bore		Dimension			d1	Grade L	Grade R	kg	kg	Dimension			A	Wt.	h3	i	b2	I2	M	N	P	Q	V1	V2	t	Wt.	TL		
	DN1	DN2	a	f	h1						R	R	d2																	b3
32-200 40-200 50-160	50 65 80	32 40 50	80 80 100	360 360 360	160 160 160	180 180 180	24 24 24	36 37 32	38 39 33	---	90L	168.5	24	320	750	0	33	250	55	290	480	200	50	4	MI2	115	155	3	1.1	795.5
										100L	193	28	320	750	0	33	250	55	290	480	200	50	4	MI2	115	155	3	1.6	829	
										112M	200	28	320	750	0	32	250	55	290	480	200	50	4	MI2	115	155	3	1.6	854.5	
										132S	239	38	350	870	0	34	250	90	320	600	200	50	4	MI2	150	120	3	3.2	917	
										160M*	323	42	430	1000	0	39	250	110	400	660	200	50	4	MI2	170	170	3	6.7	1071	
										160M**	323	42	430	1000	0	39	250	110	400	660	200	50	4	MI2	170	170	3	6.7	786	
										160L	345	42	430	1000	0	39	250	110	400	660	200	50	4	MI2	170	170	3	6.7	1115	
										160L	345	42	430	1000	0	39	250	110	400	660	200	50	4	MI2	170	170	3	6.7	1115	
										180M	351.5	48	430	1000	0	42	270	110	400	660	200	50	4	MI2	170	170	3	9.0	1107	
										112M	200	28	320	750	0	32	250	55	290	480	200	50	4	MI2	115	155	3	1.6	854.5	
										132S	239	38	350	870	0	34	250	90	320	600	200	50	4	MI2	150	120	3	3.2	917	
										160M*	323	42	430	1000	0	39	250	110	400	660	200	50	4	MI2	170	170	3	6.7	1071	
160M**	323	42	430	1000	0	39	250	110	400	660	200	50	4	MI2	170	170	3	6.7	786											
160L*	345	42	430	1000	0	39	250	110	400	660	200	50	4	MI2	170	170	3	6.7	1115											
160L**	345	42	430	1000	0	39	250	110	400	660	200	50	4	MI2	170	170	3	6.7	1115											
180MA	351.5	48	430	1000	0	42	270	110	400	660	200	50	4	MI2	170	170	3	9.0	1135											
180M*	351.5	48	430	1000	0	42	270	110	400	660	200	50	4	MI2	170	170	3	9.0	1107											
180M**	351.5	48	430	1000	0	42	270	110	400	660	200	50	4	MI2	170	170	3	9.0	1040											
180L	370.5	55	430	1000	0	42	270	110	400	660	200	50	4	MI2	170	170	3	13.9	1145											
200LA	395.5	55	470	1120	0	53	292	130	440	740	200	50	4	MI2	190	190	3	13.9	1233											
200L	395.5	55	470	1120	0	53	292	130	440	740	200	50	4	MI2	190	190	3	13.9	1213.5											
225S	402	55	530	1250	10	71	342	145	490	840	250	63	4	MI6	205	205	3	13.9	1230											
132S	239	38	350	1000	0	33	250	110	320	660	200	50	4	MI2	170	170	3	3.2	1052											
160M*	323	42	430	1120	0	36	250	130	400	740	200	50	4	MI2	190	190	3	6.7	1206											
160M**	323	42	430	1120	0	36	250	130	400	740	200	50	4	MI2	190	190	3	6.7	921											
160L*	345	42	430	1120	0	36	250	130	400	740	200	50	4	MI2	190	190	3	6.7	1250											
160L**	345	42	430	1120	0	36	250	130	400	740	200	50	4	MI2	190	190	3	6.7	1168.5											
180MA	351.5	48	430	1120	0	44	270	130	400	740	200	50	4	MI2	190	190	3	9.0	1270											
180M*	351.5	48	430	1120	0	44	270	130	400	740	200	50	4	MI2	190	190	3	9.0	1242											
180M**	351.5	48	430	1120	0	44	270	130	400	740	200	50	4	MI2	190	190	3	13.9	1175											
180L	370.5	55	430	1120	0	44	270	130	400	740	200	50	4	MI2	190	190	3	13.9	1280											
200LA	395.5	55	470	1250	10	63	317	145	430	840	250	63	4	MI6	205	205	3	13.9	1368											
200L	395.5	55	470	1250	10	63	317	145	430	840	250	63	4	MI6	205	205	3	13.9	1348.5											
225MA	414.5	55	530	1250	10	69	342	130	490	840	250	63	4	MI6	205	205	3	13.9	1409											
225M	414.5	55	530	1250	10	69	342	130	490	840	250	63	4	MI6	205	205	3	13.9	1462.5											
250SA	463.5	60	530	1250	10	76	370	130	490	840	250	63	4	MI6	205	205	3	21.0	1481.5											
250M	452.5	55	530	1250	10	76	370	130	490	840	250	63	4	MI6	205	205	3	13.9	1526											
32-250 40-250 50-250 80-250	50 65 80 100	32 40 50 80	100 100 100 125	470 470 470 470	180 180 180 225	225 225 225 250	32 32 32 32	54 55 57 60	56 58 59 62	---	112M	200	28	380	870	0	38	270												

Dimension Chart

Dimension Chart for 4P Motor Drive (continuation)

Pump Sizes	Pump								Motor		Base Plate				Foundation Dimensions										Coupling		Refer.		
	Bore		Dimension			Axle		Grade L	Grade R	Dimension		b3	i3	A	Wt.	h3	i	b2	i2	M	N	P	Q	V1	V2	t		Wt.	TL
	DN1	DN2	a	f	h1	h2	d1			R	d2																		
125-400 200-240 200-250	150	125	140	530	315	400	42	165	182	160L	345	48	590	1250	10	90	435	95	550	840	250	63	4	M16	205	205	3	9.0	1263.5
										180MC	351.5	48	590	1250	10	90	435	95	550	840	250	63	4	M16	205	205	3	9.0	1365
										180M*	351.5	48	590	1250	10	90	435	95	550	840	250	63	4	M16	205	205	3	9.0	1337
										180M**	351.5	55	590	1250	10	90	435	95	550	840	250	63	4	M16	205	205	3	13.9	1278
										180LC	370.5	48	590	1250	10	90	435	95	550	840	250	63	4	M16	205	205	3	9.0	1403
										180L*	370.5	55	590	1250	10	90	435	95	550	840	250	63	4	M16	205	205	3	13.9	1375
										180L**	400.5	60	590	1250	10	90	435	95	550	840	250	63	4	M16	205	205	4	21.0	1367
										200M	406.5	65	590	1400	10	99	435	120	550	940	250	63	4	M16	230	230	4	21.0	1401.5
										200LC	395.5	55	590	1400	10	99	435	120	550	940	250	63	4	M16	230	230	3	13.9	1463
										200L*	395.5	55	590	1400	10	99	435	120	550	940	250	63	4	M16	230	230	3	13.9	1488.5
										200L**	425.5	60	590	1400	10	99	435	120	550	940	250	63	4	M16	230	230	4	21.0	1474.5
										225SC	432	60	590	1400	10	95	435	120	550	940	250	63	4	M16	230	230	4	21.0	1510
										225S*	432	60	590	1400	10	95	435	120	550	940	250	63	4	M16	230	230	4	21.0	1506
										225S**	432	65	590	1400	10	95	435	120	550	940	250	63	4	M16	230	230	4	21.0	1491
										225S***	432	75	590	1400	10	95	435	120	550	940	250	63	4	M16	230	230	4	31.0	1551
										225MC	444.5	60	590	1400	10	95	435	120	550	940	250	63	4	M16	230	230	4	21.0	1535
										225M*	444.5	60	590	1400	10	95	435	120	550	940	250	63	4	M16	230	230	4	21.0	1588.5
										225M**	444.5	75	590	1400	10	95	435	120	550	940	250	63	4	M16	230	230	4	31.0	1551
										250SC	463.5	70	640	1400	10	99	435	120	600	940	250	63	4	M16	230	230	4	31.0	1576.5
										250S	463.5	75	640	1400	10	99	435	120	600	940	250	63	4	M16	230	230	4	31.0	1574
										250MC	482.5	70	640	1400	10	99	435	120	600	940	250	63	4	M16	230	230	4	31.0	1614.5
										250M*	482.5	65	640	1400	10	99	435	120	600	940	250	63	4	M16	230	230	4	21.0	1627.5
										250M**	482.5	75	640	1400	10	99	435	120	600	940	250	63	4	M16	230	230	4	31.0	1652
										280SB	544	80	710	1600	10	109	435	160	670	1060	250	63	4	M16	270	270	4	45.0	1765.5
280S	514	75	710	1600	10	109	435	160	670	1060	250	63	4	M16	270	270	4	31.0	1718.5										
280M*	539.5	75	710	1600	10	109	435	160	670	1060	250	63	4	M16	270	270	4	31.0	1769.5										
280M**	569.5	85	710	1600	10	109	435	160	670	1060	250	63	4	M16	270	270	4	45.0	1777										
150-310 150-315 150-390 150-400	200	150	160	530	315	400	48	188	198	180MC	351.5	48	590	1250	10	90	435	95	550	840	250	63	4	M16	205	205	3	9.0	1365
										180M*	351.5	48	590	1250	10	90	435	95	550	840	250	63	4	M16	205	205	3	9.0	1337
										180M**	351.5	55	590	1250	10	90	435	95	550	840	250	63	4	M16	205	205	3	13.9	1278
										180LC	370.5	48	590	1250	10	90	435	95	550	840	250	63	4	M16	205	205	3	9.0	1403
										180L*	370.5	55	590	1250	10	90	435	95	550	840	250	63	4	M16	205	205	3	13.9	1375
										180L**	400.5	60	590	1250	10	90	435	95	550	840	250	63	4	M16	205	205	4	21.0	1367
										200M	406.5	65	590	1400	10	99	435	120	550	940	250	63	4	M16	230	230	4	21.0	1401.5
										200LC	395.5	55	590	1400	10	99	435	120	550	940	250	63	4	M16	230	230	3	13.9	1463
										200L*	395.5	55	590	1400	10	99	435	120	550	940	250	63	4	M16	230	230	3	13.9	1488.5
										200L**	425.5	60	590	1400	10	99	435	120	550	940	250	63	4	M16	230	230	4	21.0	1474.5
										225SC	432	60	590	1400	10	95	435	120	550	940	250	63	4	M16	230	230	4	21.0	1510
										225S*	432	60	590	1400	10	95	435	120	550	940	250	63	4	M16	230	230	4	21.0	1506
										225S**	432	65	590	1400	10	95	435	120	550	940	250	63	4	M16	230	230	4	21.0	1491
										225S***	432	75	590	1400	10	95	435	120	550	940	250	63	4	M16	230	230	4	31.0	1551
										225MC	444.5	60	590	1400	10	95	435	120	550	940	250	63	4	M16	230	230	4	21.0	1535
										225M*	444.5	60	590	1400	10	95	435	120	550	940	250	63	4	M16	230	230	4	21.0	1588.5
										225M**	444.5	75	590	1400	10	95	435	120	550	940	250	63	4	M16	230	230	4	31.0	1551
										250SC	463.5	70	640	1400	10	99	435	120	600	940	250	63	4	M16	230	230	4	31.0	1576.5
										250S*	463.5	75	640	1400	10	99	435	120	600	940	250	63	4	M16	230	230	4	31.0	1574
										250S**	493.5	85	640	1400	10	99	435	120	600	940	250	63	4	M16	230	230	4	45.0	1551
										250MC	482.5	70	640	1400	10	99	435	120	600	940	250	63	4	M16	230	230	4	31.0	1614.5
										250M*	482.5	65	640	1400	10	99	435	120	600	940	250	63	4	M16	230	230	4	21.0	1627.5
										250M**	482.5	75	640	1400	10	99	435	120	600	940	250	63	4	M16	230	230	4	31.0	1652
										250M***	512.5	85	640	1400	10	99	435	120	600	940	250	63	4	M16	230	230	4	45.0	1606
280SB	544	80	710	1600	10	109	435	160	670	1060	250	63	4	M16	270	270	4	45.0	1765.5										
280S*	514	75	710	1600	10	109	435	160	670	1060	250	63	4	M16	270	270	4	31.0	1718.5										
280S**	544	85	710	1600	10	109	435	160	670	1060	250	63	4	M16	270	270	4	45.0	1726										
280MB	569.5	80	710	1600	10	109	435	160	670	1060	250	63	4	M16	270	270	4	45.0	1816										
280M*	539.5	75	710	1600	10	109	435	160	670	1060	250	63	4	M16	270	270	4	31.0	1769.5										
280M**	569.5	85	710	1600	10	109	435	160	670	1060	250	63	4	M16	270	270	4	45.0	1777										
315SB	589	85	710	1600	10	109	445	160	670	1060	250	63	4	M16	270	270	4	61.0	1855										

*Motor frame is the same but shaft axle diameter (d2) is different.

TU Motor (Torishima Ultra High Efficiency Motor)



Torishima pursues high efficiency for not only pump but motor.

IEC (International Electrotechnical Commission) classifies IE1 (standard), IE2 (high efficiency), IE3 (premium efficiency) by motor efficiency. TU motor is equivalent to IE3.

Relation between motor efficiency and output (60Hz)

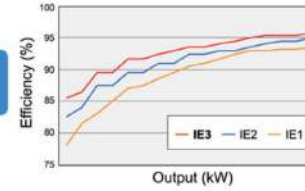

Class in IEC60034-30

	Class
TU motor	IE3
High Efficiency Motor (JIS C 4212)	IE2
Standard Motor (JIS C 4210)	IE1

in case of 50Hz-200V/400V, 60Hz-220V/440V

Copper Loss